

Computerized Code Machines

ITL 950C



ITL 950

- Ideal for mobile units.
- Medeco/ Emhart™ head and program included
- 600+ spaces & depths
- 99 custom tables for new spaces & depths
- Laser cut mode
- Half cut mode for progression
- Communication port
- One cutter does it all (with minor exceptions)
- Repeatable accuracy of X-Y axis: +/- .002"
- Power: 120 volt AC & 12 volt DC (standard)
- Keypad: 20 key-sealed membrane
- Display: 2 lines, 16 characters per line
- Dimensions: 14"L x 11"W x 9"H
- Net Weight: 36 lbs

- Every feature of the ITL 950 plus the following additional features.
- Codes for international car manufacturers included.
- Dual voltage for shop and mobile
- 99 custom tables for new spaces & depths
- Built-in automotive codes with inserts for double-sided automotive keys
- Communication Port to Computer
- Modes: Normal (cut by cut), laser, Half-cut for progression
- Dimensions: 14"L x 11"W x 9"H
- Keypad: Alpha-numeric
- Display: 4 lines, 20 characters per line

ITL 9700A

- Industrial use machine has every function of the ITL 950 plus the following additional features.
- Fast, powerful and precise. Built for industrial use.
- Medeco™ Auto Rotation Head
- 99 custom tables for new spaces & depths
- Communication Port to Computer
- Compatible with majority of commercially available software
- Power: 120 volt AC (standard)
- Typical cut rates: - Standard 15 seconds, High-Speed 9 seconds, Laser 8 seconds, Biaxial 6 pin 16 seconds
- Repeatable accuracy: +/- .00075"
- Dimensions: 16"L x 15"W x 12"H
- Display: 2 lines, 16 characters per line
- Net Weight: 78lbs

Mfg #	Type	EZ #
ITL950	Mobile Use	039432
ITL950C	Mobile & Shop Use	076660
ITL9700A	Heavy Duty Shop Use	076661

Automatic Safe Dialer

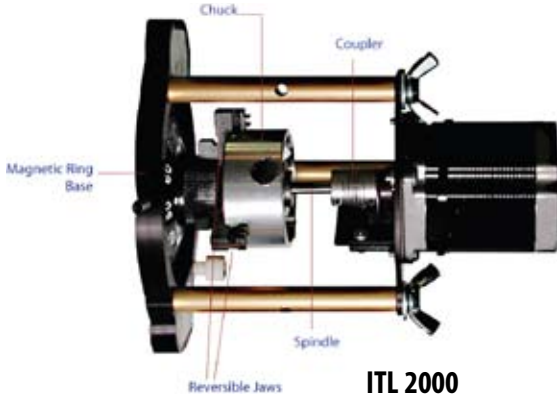

ITL 2000

- Operates without supervision - set up and run until combination lock opens.
- Compact carrying case measuring 18"L x 13.5"W x 5.5"H
- Weight: 15lbs
- Power: 110 or 220 VAC
- Easy 15 minute set-up
- Average opening time is 6 hours
- Non-invasive. Safes remain intact and costly repairs are avoided.
- 4 dialing speeds for loose wheels packs.
- Safe lock can be dialed to every possible safe lock combination through a specific range of numbers.

- Dialer mount attached by strong rare earth magnets.
- Opens: S&G 6720-30, Lagard LAG 1777, Ilco 673LKS and any safe lock that has a lever arm with a lever nose that rides on the drive cam which in turn pulls back the lock bolt when the wheel pack gates are aligned.
- Will not open manipulation proof safe locks.
- Reversible jaws grip most dials
- **Optional Extras**
- Jaw set for larger dials
- Adjustable mount plate kit

Mfg #	EZ #
ITL2000	101043